

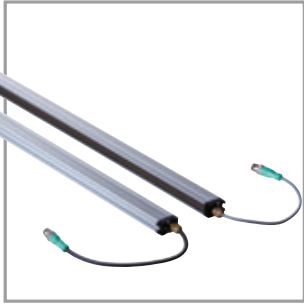

THE FUTURE BELONGS TO IO-LINK

 **IO-Link**



With its simple approach and cost-saving potential, IO-Link impresses across the board, from plant design through installation to operation and maintenance.

## AT A GLANCE

- Long-term cost reductions at all levels
- Standardized for easy operation
- Minimized downtimes through intelligent parameter management
- Comprehensive device diagnosis down to field level
- Enhanced flexibility in application
- Long-term investment security thanks to international standardization

Communication

Planning • Installation • Operation • Service

## INVESTMENT WITH A FUTURE

IO-Link enables continuous communication at the sensor level. Sensor intelligence is fully integrated, opening up new opportunities in automation.

IO-Link sensors from Pepperl+Fuchs can be operated on any master, irrespective of the system. Existing wiring and connection systems can be used.

Equip your plant for the future so that you can benefit from the many functions of IO-Link and save costs for many years to come. International standardization will protect your investment in the long term.

 **IO-Link**

## THE STANDARD

IO-Link is an international manufacturer-independent standard based on IEC 61131-9. Many well-known manufacturers recognize the standardized communication interface and support IO-Link on the market. As a leading member of the IO-Link Consortium, Pepperl+Fuchs has been working on the IO-Link specification with a view to defining IO-Link as the standard for the future.

## PLANNING

- Economy of Scale
- Greater flexibility in planning
- Lower volume of spare parts kept in stock

The connection between the sensor and master is established using a simple standard 3-wire cable. IO-Link can simultaneously transfer switching information, measured values, and status information.

ports is reduced. IO-Link can replace analog interfaces completely. Parameterization interfaces such as RS232 become superfluous because IO-Link transmits process and parameter data simultaneously. The smaller number of different versions reduces planning costs and the quantity of spare parts kept in stock.

The number of different interfaces, connection cables, and required

### REDUCED INTERFACE COMPLEXITY

- Economy of Scale
- Fewer options reduce ordering and administrative costs
- Lower volume of spare parts kept in stock

**IO-Link** = +

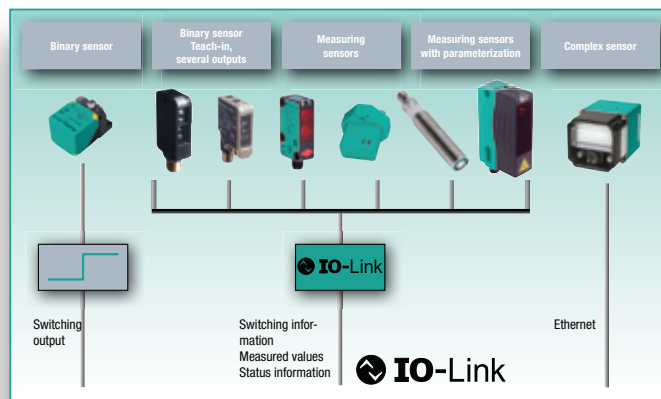
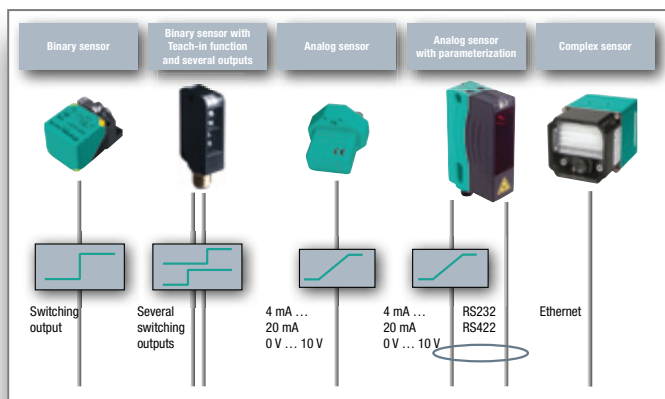

### REDUCED NUMBER OF CONTROL INPUTS

- Greater flexibility
- Lower planning costs

**IO-Link** = +

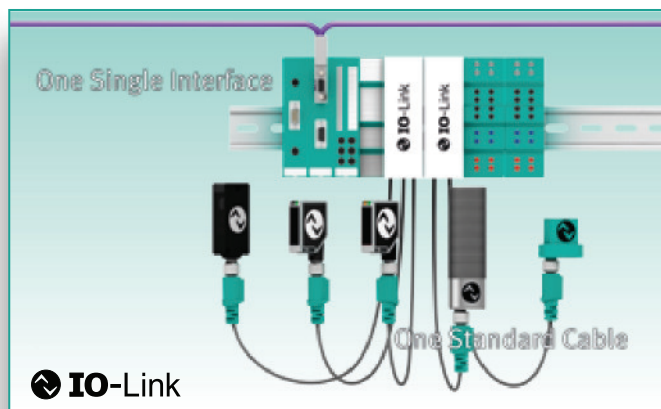
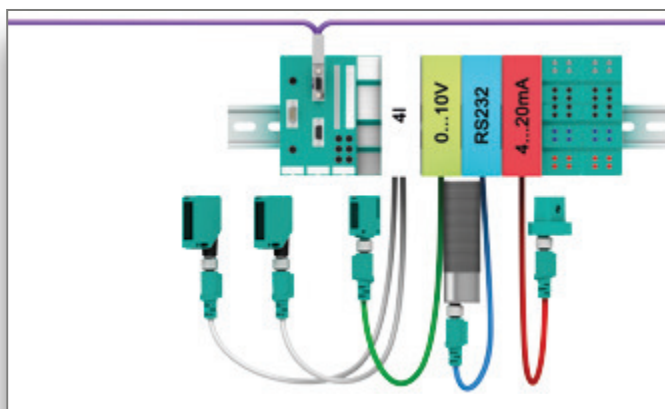

## INSTALLATION AND COMMISSIONING

- Reduced commissioning times
- Convenient operation
- Extensive diagnostic options
- Localization function

The complicated processes involved in manual device setup are no longer necessary. Individual devices can be cloned easily by transferring configuration and parameterization data from one device to another. Commissioning times for series production plants are reduced considerably as a result.

Pepperl+Fuchs provides a vast range of tools for sensor parameterization and diagnostics.

Standard operating concepts make these tools much easier to handle.

Extensive diagnostic options are available during setup. A measured value and the stability or strength of a sensor signal can be checked and optimized.

### STANDARDIZED INTERFACE

- Reduced installation and commissioning times
- Save costs on components

 **IO-Link** =  + 

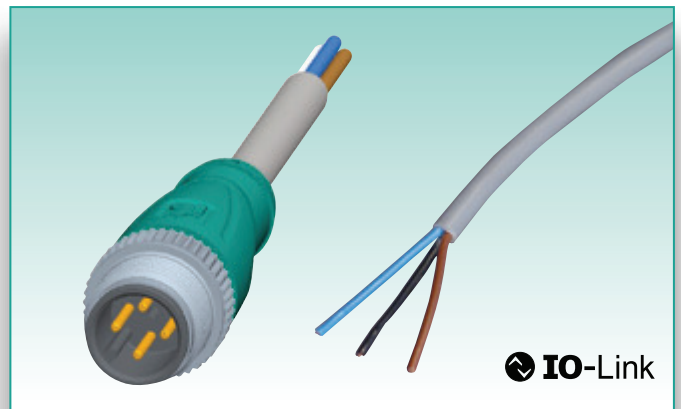
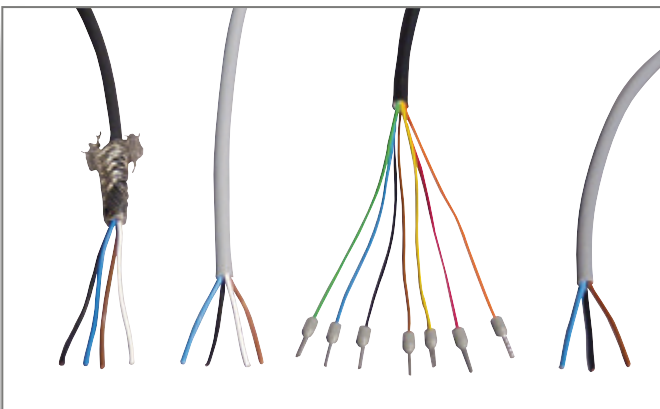

### UNIFORM, STANDARD RANGE OF TOOLS

- Simplified configuration, parameterization, and diagnosis
- Short commissioning times
- Flexible on-site or central commissioning

 **IO-Link** =  + 



## OPERATION

- Extensive diagnostic options
- Localization function
- Requirement-oriented maintenance
- Fast recipe changeovers

Extensive diagnostic options during operation provide an indication of the operating state as well as other sensor information so that dirt or wear can be detected before a system failure occurs. This calls for requirement-oriented maintenance. A sensor can be located easily in a plant using the localization function.

Automated parameterization allows the operator to change the recipe on a large number of devices almost simultaneously. Changing complicated manual settings locally on individual devices is no longer necessary.

### COMPREHENSIVE DEVICE DIAGNOSIS DOWN TO FIELD LEVEL

- Simultaneous transfer of switching information, measured values, and status information
- Evaluation of measured values locally at the sensor or centrally in the PLC
- Access to diagnostic information during normal operation
- Requirement-oriented maintenance prevents system downtime



### INTELLIGENT PARAMETER ADMINISTRATION

- Parameter change within seconds
- Recipe change without system downtime

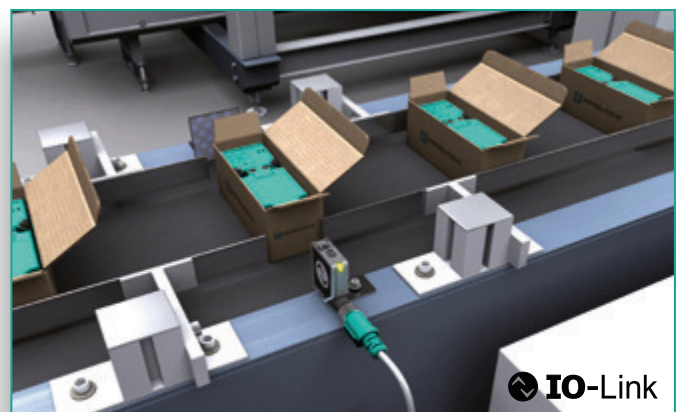
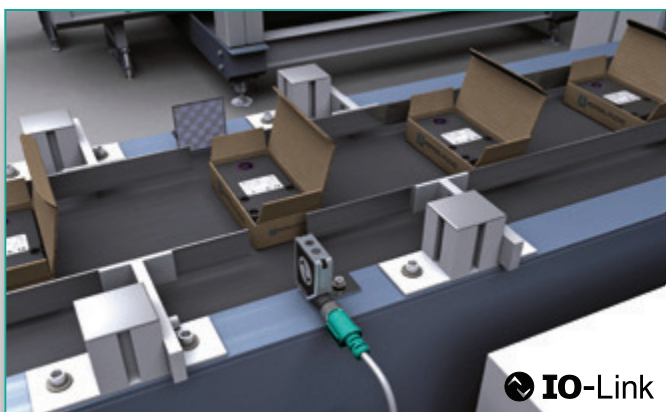

## MAINTENANCE

- Requirement-oriented maintenance
- Localization function
- Easy device replacement
- Minimized downtime

Comprehensive remote diagnosis of the sensor enables communication down to the lowest field level. The sensors can be localized accurately.

Automated parameter exchange speeds up the device replacement process significantly. The complicated manual adjustment of settings on the sensor is no longer necessary.

Extensive diagnostic options are available while the plant is operating. These options allow you to customize requirement-oriented maintenance cycles, guaranteeing a much higher degree of plant availability.

### COMPREHENSIVE REMOTE DIAGNOSIS DOWN TO THE SENSOR

- Access to diagnostic information during normal operation
- Preventive maintenance for reduced downtime
- Localization function enables the quick, targeted replacement of devices



### CENTRAL PARAMETER STORAGE

- Rapid sensor replacement
- Automated reparameterization shortens system downtime
- SIO mode allows backwards compatibility with standard digital input/binary sensor



## FIELDBUS NEUTRALITY

- The IO-Link interface is compatible with existing fieldbuses
- No interference with existing fieldbus topologies
- IO-Link sensors from Pepperl+Fuchs work well with any system

## MIXED OPERATION POSSIBLE

- In addition to IO-Link sensors, conventional binary sensors can be connected to the IO-Link master
- Backwards compatible with standard digital input/binary sensor

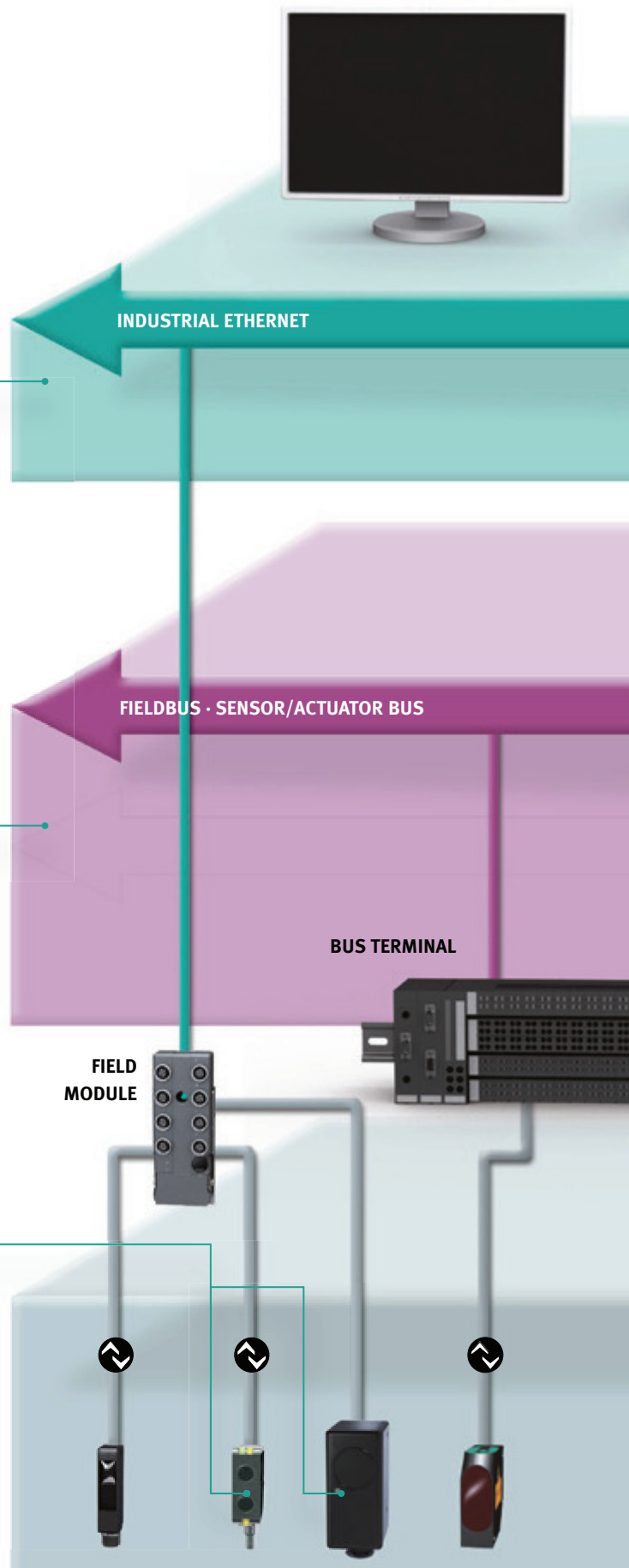
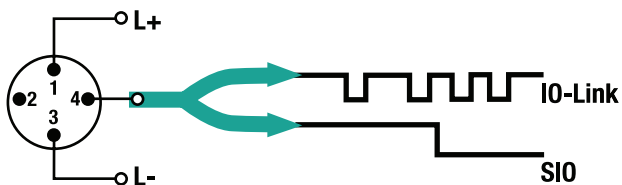



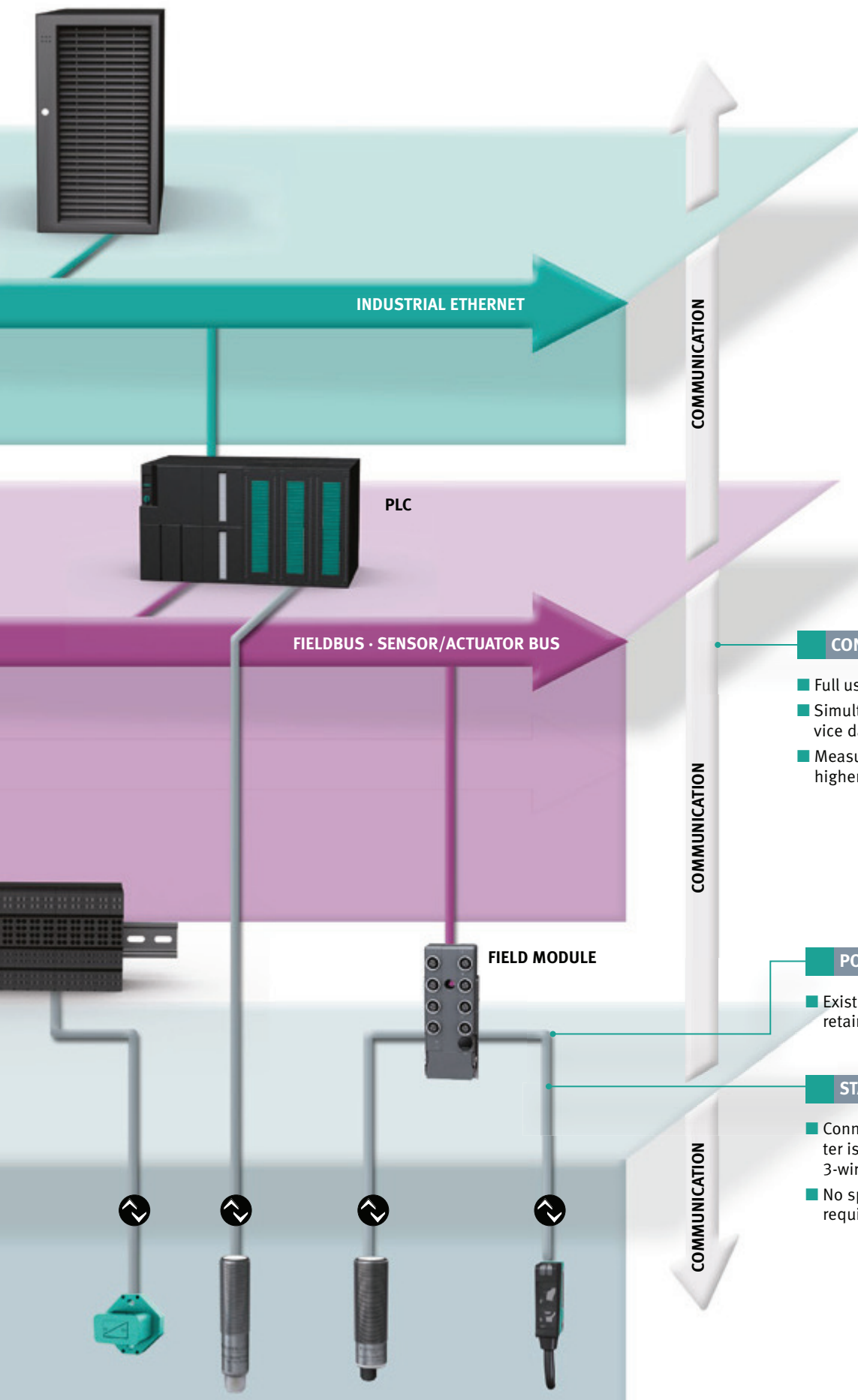

**CONSISTENT COMMUNICATION**

- Full use of sensor intelligence and functions
- Simultaneous transfer of process and service data (parameter and diagnostic data)
- Measured values and data are available to higher-level systems without restriction

**POINT-TO-POINT CONNECTION**

- Existing connection topologies are retained

**STANDARD SENSOR/ACTUATOR CABLES**

- Connection between the sensor and master is established using a simple standard 3-wire cable
- No special cable or connectors are required

Pepperl+Fuchs offers you a vast range of tools for sensor parameterization and diagnostics. Standard operating concepts offer greater convenience and simplify overall handling.

## FDT



FDT (Field Device Tool) is a standard for normalizing the interface between the device and the operator interface. Device operation can be integrated quickly and easily using the FDT.

## IODD INTERPRETER

Software for integrating IODDs in a FDT operator interface, e.g., **PACTware™**. The IODD Interpreter “translates” the IODD and prepares the information it contains for the FDT base application by adapting the parameters to the same format as DTM device parameters.

## PACTWARE



**PACTware™** is an open, manufacturer-independent user interface compatible with all fieldbuses according to FDT standards that enables the operation of devices, systems, and communication components throughout the plant.

## DEVICE-SPECIFIC DTM

In addition to the ever-present IODDs, specific DTMs (Device Type Manager) are available for IO-Link sensors. The device DTMs allow the convenient operation of sensors via a graphical user interface for visualizing and interpreting configuration, parameter, and diagnostic data.

## IO-LINK USB MASTER

The IO-Link USB master can parameterize any sensor quickly and easily using standardized **PACTware™**, IODD Interpreter tools, and a PC.

## IODD

The IODD (IO Device Description) is a standardized, XML-based description of the function and parameters of an IO-Link sensor. The system tools open a user interface for parameterizing and diagnosing IO-Link devices. The IODD can be used throughout the system. There is one IODD available for each IO-Link device.

## IO-LINK GATEWAY DTM

The IO-Link gateway DTM is required to establish communication to an IO-Link device via the IO-Link USB master for operation within a FDT operator interface.

PACTware operator interface

Device-specific DTM using the example of a DTM for VDM28 distance sensors

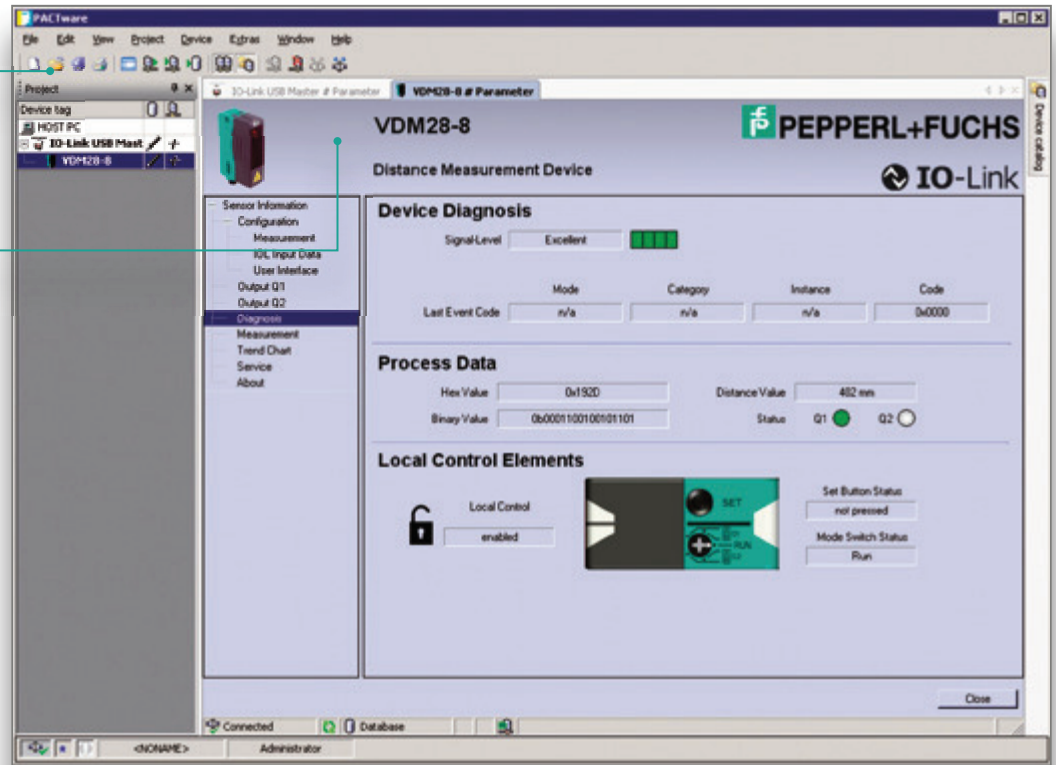



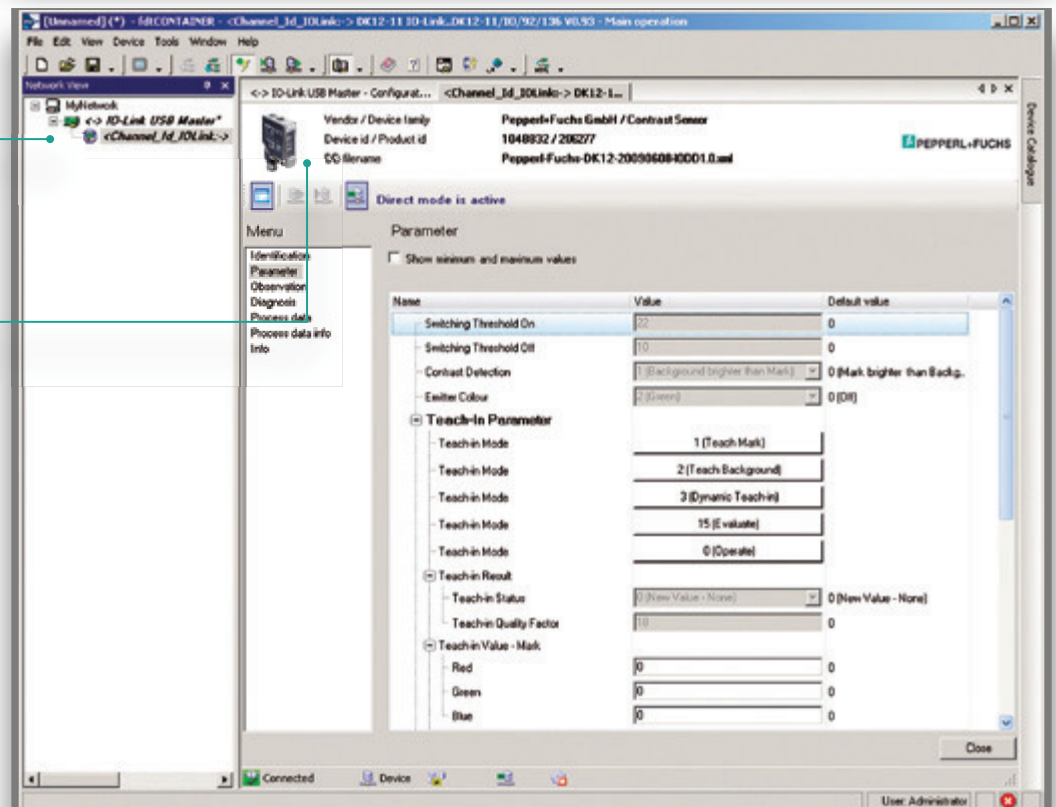

Alternative FDT operator interface

IODD Interpreter and DTM using the example of the IODD of a DK12 print mark contrast sensor

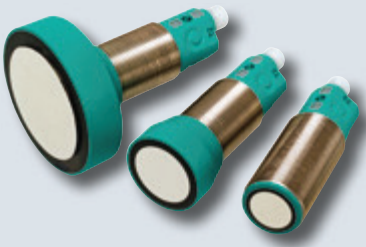

IO-Link Portfolio	Product name	Applications
<p><b>Distance measurement sensors</b></p> 	<p>VDM28-8-L VDM28-50-R VDM28-15-L</p>	<ul style="list-style-type: none"> <li>■ Positioning</li> <li>■ Fill level measurement</li> <li>■ Distance measurement</li> <li>■ Collision prevention</li> </ul>
<p><b>Automation light grids</b></p> 	<p>LGS8 LGS17 LGS25 LGS50 LGS100</p>	<ul style="list-style-type: none"> <li>■ Object detection and identification</li> <li>■ Height and tension checks</li> <li>■ Measurement of object size using obstructed beams</li> <li>■ Suitable for cold storage warehouse applications</li> </ul>
<p><b>Background suppression sensor</b></p> 	<p>RL31-8-H</p>	<ul style="list-style-type: none"> <li>■ Presence checks</li> <li>■ Tension checks</li> <li>■ Stroke height monitoring</li> <li>■ Fill level monitoring</li> <li>■ Collision prevention</li> </ul>
<p><b>Print mark contrast sensor</b></p> 	<p>DK12-11</p>	<ul style="list-style-type: none"> <li>■ Print mark detection</li> <li>■ Label control</li> </ul>
<p><b>Retroreflective sensors and background suppression sensors</b></p> 	<p>MLV41-6 MLV41-55 MLV41-54-G MLV41-8-H-120 MLV41-8-H-500</p>	<ul style="list-style-type: none"> <li>■ Presence checks</li> <li>■ Tension checks</li> <li>■ Web break monitoring</li> <li>■ Monitoring stack heights and track loading</li> </ul>

	Main features	Technical data
	<ul style="list-style-type: none"> <li>■ Measurement to object or reflector</li> <li>■ Small, clearly visible red light spot</li> <li>■ High degree of repeatability irrespective of the surface</li> <li>■ Minimal black-white difference</li> <li>■ Two switching points per output</li> <li>■ Immune to ambient lighting</li> <li>■ No cross-talk</li> </ul>	<ul style="list-style-type: none"> <li>■ Measuring ranges up to 8 m, 15 m, and 50 m</li> <li>■ Laser light class 1 or 2</li> <li>■ Repeat accuracy &lt; 5 mm</li> <li>■ Operating voltage 10 VDC ... 30 VDC</li> <li>■ Pulse Ranging Technology</li> </ul>
	<ul style="list-style-type: none"> <li>■ Lightning-speed object detection</li> <li>■ Beam crossover with no reduction in response time</li> <li>■ Slimline housing design with integrated control</li> <li>■ Software-free adjustment using touch field</li> <li>■ Integrated object detection</li> <li>■ Standby mode provides reduced power consumption and long service life</li> </ul>	<ul style="list-style-type: none"> <li>■ Sensing range 0.3 m ... 8 m</li> <li>■ Optical resolution 4 mm ... 100 mm</li> <li>■ Device height 100 mm ... 3200 mm</li> <li>■ Beam gaps 8 mm ... 100 mm</li> <li>■ 3-way beam crossover possible</li> <li>■ Degree of protection IP67</li> <li>■ Temperature range down to -30 °C</li> </ul>
	<ul style="list-style-type: none"> <li>■ Measuring photoelectric sensor</li> <li>■ PowerBeam transmitter LED</li> <li>■ Large, precision-adjustable sensing range</li> <li>■ Various operating modes available</li> <li>■ Consistently small BW/WB difference up to final detection range</li> </ul>	<ul style="list-style-type: none"> <li>■ Sensing range 50 mm ... 800 mm</li> <li>■ BW/WB difference &lt; 5 %</li> <li>■ Operating voltage 10 VDC ... 30 VDC</li> <li>■ Degree of protection IP67</li> </ul>
	<ul style="list-style-type: none"> <li>■ Detects print marks of any color</li> <li>■ Reliable detection, even with low contrast and reflective surfaces</li> <li>■ Suitable for high-speed scanning processes</li> <li>■ 3 transmitter colors: green, red, and blue</li> </ul>	<ul style="list-style-type: none"> <li>■ Detection range 11 mm</li> <li>■ Response time 50 µs</li> <li>■ Light spot image</li> <li>■ Teach-In: dynamic, static, external</li> </ul>
	<ul style="list-style-type: none"> <li>■ PowerBeam transmitter LED</li> <li>■ Clearly visible LED function displays</li> <li>■ Short circuit and undervoltage indicator</li> <li>■ Housing resistant to acids and alkalis</li> <li>■ MLV41-54-G for reliable detection of transparent objects</li> <li>■ MLV41-8-H with large, precision-adjustable sensing range</li> <li>■ Various operating modes available</li> <li>■ Consistently small BW/WB difference up to final detection range</li> </ul>	<ul style="list-style-type: none"> <li>■ Operating voltage 10 VDC ... 30 VDC</li> <li>■ MLV41-6: detection range 0,1 m – 9,5 m</li> <li>■ MLV41-55: detection range 0,1 m – 8 m</li> <li>■ MLV41-54-G: detection range 0 m – 5 m</li> <li>■ MLV41-8-H-120: detection range 20 mm ... 120 mm, BW/WB difference &lt; 3 %</li> <li>■ MLV41-8-H-500: detection range 20 mm ... 500 mm, BW/WB difference &lt; 5 %</li> </ul>

	IO-Link Portfolio	Product name	Applications
POSITIONING SYSTEMS	<b>Inductive positioning system</b> 	PMI14V	<ul style="list-style-type: none"> <li>Positioning</li> <li>Distance measurement</li> <li>Equipment condition monitoring</li> </ul>
	<b>30GM ultrasonic sensors</b> 	UC500-30GM UC2000-30GM UC4000-30GM UC6000-30GM	<ul style="list-style-type: none"> <li>Positioning</li> <li>Fill level measurement</li> <li>Distance measurement</li> <li>Collision prevention</li> </ul>
ULTRASONIC SENSORS	<b>18GM ultrasonic sensors</b> 	UC1000-18GM	<ul style="list-style-type: none"> <li>Positioning</li> <li>Fill level measurement</li> <li>Distance measurement</li> <li>Collision prevention</li> </ul>
ACCESSORIES	<b>IO-Link USB master</b> 	IO-Link-Master01-USB	<ul style="list-style-type: none"> <li>Parameterization of IO-Link devices</li> <li>Diagnostic tool for maintenance</li> </ul>
	<b>IO-Link interface</b> 	IO-Link-Interface-01	<ul style="list-style-type: none"> <li>Interface between standard sensors and IO-Link system</li> <li>Preprocessing of signals</li> </ul>

	Main features	Technical data
	<ul style="list-style-type: none"> <li>■ <b>Noncontact inductive position measurement</b></li> <li>■ <b>Enhanced position resolution and measured value stability</b></li> <li>■ <b>Digital processing of position data</b></li> </ul>	<ul style="list-style-type: none"> <li>■ Signal output as IO-Link process data and an analog voltage value 0 V ... 10 V</li> <li>■ Programmable measuring range from 0 mm ... 14 mm</li> <li>■ High position value resolution of <math>\leq 33 \mu\text{m}</math></li> <li>■ Operating voltage 18 VDC ... 30 VDC</li> <li>■ High degree of protection IP67</li> </ul>
	<ul style="list-style-type: none"> <li>■ <b>Measurement directly to object</b></li> <li>■ <b>Programmable sound cone width</b></li> <li>■ <b>High degree of repeatability irrespective of the surface</b></li> <li>■ <b>Two switching points per output</b></li> <li>■ <b>Insensitive to ambient light, object color, and dirt</b></li> <li>■ <b>No cross-talk</b></li> </ul>	<ul style="list-style-type: none"> <li>■ Distance is output as IO-Link process data or an analog value 0 V ... 10 V or 0/4 mA ... 20 mA</li> <li>■ Two programmable switching points</li> <li>■ Operating voltage 10/15 VDC ... 30 VDC</li> <li>■ High degree of protection IP67</li> <li>■ Ambient temperature range <math>-25 \text{ }^\circ\text{C}</math> ... <math>+70 \text{ }^\circ\text{C}</math></li> </ul>
	<ul style="list-style-type: none"> <li>■ <b>Measurement directly to object</b></li> <li>■ <b>High degree of repeatability irrespective of the surface</b></li> <li>■ <b>Two switching points per output</b></li> <li>■ <b>Insensitive to ambient light, object color, and dirt</b></li> <li>■ <b>No cross-talk</b></li> </ul>	<ul style="list-style-type: none"> <li>■ Distance is output as IO-Link process data or an analog value</li> <li>■ Operating voltage 20 VDC ... 30 VDC</li> <li>■ High degree of protection IP67</li> <li>■ Ambient temperature range <math>-25 \text{ }^\circ\text{C}</math> ... <math>+70 \text{ }^\circ\text{C}</math></li> </ul>
	<ul style="list-style-type: none"> <li>■ <b>Connection to a PC via USB</b></li> <li>■ <b>Compact, flexible</b></li> <li>■ <b>Full IO-Link master functionality</b></li> <li>■ <b>Communication DTM for operating in any FDT environment</b></li> </ul>	<ul style="list-style-type: none"> <li>■ IO-Link master with USB2 connection</li> <li>■ Operating voltage 20 VDC ... 30 VDC</li> </ul>
	<ul style="list-style-type: none"> <li>■ <b>Connection of up to 2 binary or analog sensors</b></li> <li>■ <b>Speed, rotation direction, or standstill detection</b></li> <li>■ <b>Counter and timer function</b></li> </ul>	<ul style="list-style-type: none"> <li>■ 2 digital or analog inputs</li> <li>■ 2 digital outputs, option of selecting PNP or NPN</li> <li>■ Connection via standard M12 plug</li> <li>■ Operating voltage 20 VDC ... 30 VDC</li> </ul>

# YOUR APPLICATION. OUR CHALLENGE.

## PROCESS INTERFACES

- Intrinsically safe barriers
- Signal conditioners
- Fieldbus infrastructure
- Remote I/O systems
- HART interface solutions
- Level measurement
- Purge and pressurization systems
- Industrial monitors and HMI solutions
- Explosion protection equipment
- Wireless solutions
- Solutions for process interfaces

## INDUSTRIAL SENSORS

- Proximity sensors
- Photoelectric sensors
- Industrial vision
- Ultrasonic sensors
- Rotary encoders
- Positioning systems
- Inclination and acceleration sensors
- AS-Interface
- Identification systems
- Logic control units



[www.pepperl-fuchs.com](http://www.pepperl-fuchs.com)

 **PEPPERL+FUCHS**